

**Dimensioni motori trifase
autofrenanti e doppia
polarità autofrenanti
serie AT - AD - AH - AI -
TA** - AS - AC**

**Dimensions of three-
phase brake motors and
two-speed brake motors
series AT - AD - AH - AI -
TA** - AS - AC**

**Dimensions des moteurs
triphases autofreinants et
à double polarité
autofreinants série AT - AD
AH - AI - TA** - AS - AC**

**Abmessungen der
Drehstrombremsmotoren
und der polumschaltbaren
Bremsmotoren Serie AT -
AD - AH AI - TA** - AS - AC**

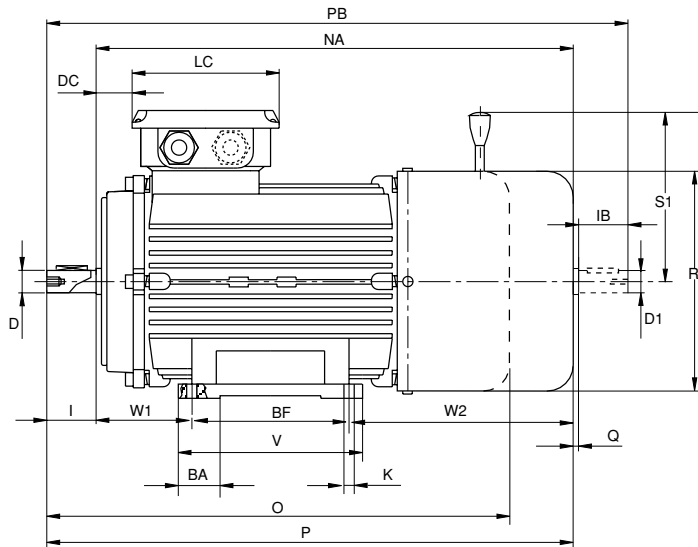
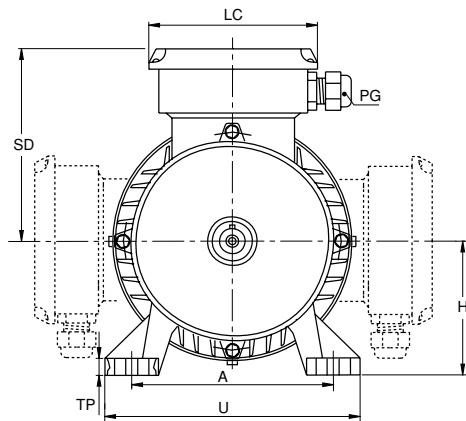

B3

Grandezza Size Grandeur Größe	Dimensioni / Dimensions / Dimensions / Abmessungen																				B3				
	D1	D	I	A	BF	K	H	W1	W2	NA	O*	PG	R	SD	TP	U	V	PB	Q	LC		DC	IB	BA	P
56	9	9	20	90	71	6	56	36	105	212	-	M16	110	108	10	108	90	255	3	93	15	20	25	232	90
63	11	11	23	100	80	7	63	40	119	239	233	M16	123	117	10	120	105	288	3	93	12	23	27	262	98
71	11	14	30	112	90	8	71	48	128	266	245	M16	137	124	11	136	108	322	3	93	23	23	24	296	98
80	14	19	40	125	100	9	80	54	144	298	278	M20	156	141	13/14	154	125	371	3	115	26	30	30	338	111
90S	14	24	50	140	100	10	90	59	151	310	325	M20	176	150	15	170	130	395	5	115	29	30	30	360	129
90L	14	24	50	140	125	10	90	59	151	335	350	M20	176	150	13/15	170	155	420	5	115	29	30	32	385	129
100	24	28	60	160	140	13	100	63	174	377	404	M20	194	159	15/16	192	175	492	5	115	33	50	32	437	139
112	24	28	60	190	140	13	112	72	197	409	388	M20	218	172	15	224	176	525	6	115	35	50	34	469	161
132S	28	38	80	216	140	14	132	89	253	482	463	M32	258	192	16/18	260	180	628	6	123	48	60	37	562	186
132M	28	38	80	216	178	14	132	89	253	520	500	M32	258	192	16/18	260	218	666	6	123	48	60	37	600	186
160M	42	42	110	254	210	13	160	108	309	627	602	M32	315	246	18	318	260	856	9	187	56	110	52	737	242
160L	42	42	110	254	254	13	160	108	309	671	645	M32	315	246	18	318	304	900	9	187	56	110	52	781	242
180	-	48	110	280	280	13	180	120	325	725	-	M32	348	260	24	346	330	-	-	187	51	-	42	835	320

O* = Quota per freno serie S
Grandezza 200 autofrenante disponibile su richiesta

O* = Value for series S brake
Size 200 self-braking available on request

O* = Cote pour frein série S
Grandeur 200 freinage automatique disponible sur commande

O* = Wert für die Bremse Serie S
Größe 200 selbstbremsend auf Anfrage erhältlich

**Dimensioni motori trifase
autofrenanti e doppia
polarità autofrenanti
serie AT - AD - AH - AI -
TA** - AS - AC**

**Dimensions of three-
phase brake motors and
two-speed brake motors
series AT - AD - AH - AI -
TA** - AS - AC**

**Dimensions of three-
phase brake motors and
two-speed brake motors
à double polarité
autofrenants série AT - AD
AH - AI - TA** - AS - AC**

**Abmessungen der
Drehstrombremsmotoren
und der polumschaltbaren
Bremsmotoren Serie AT -
AD - AH AI - TA** - AS - AC**

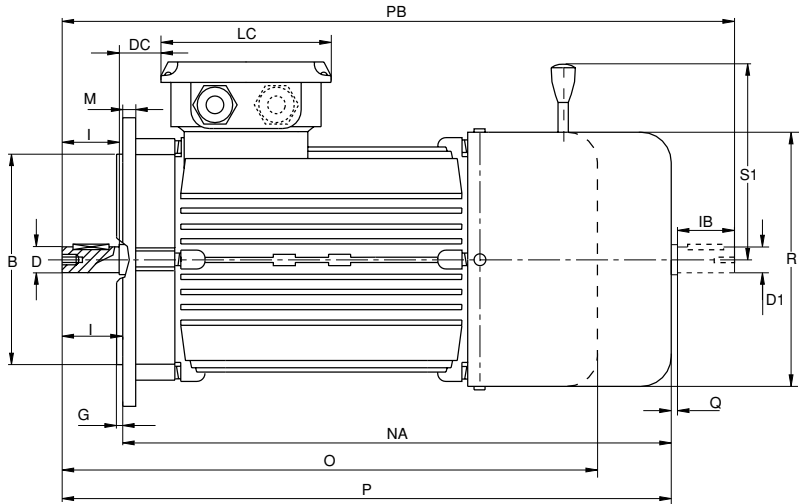
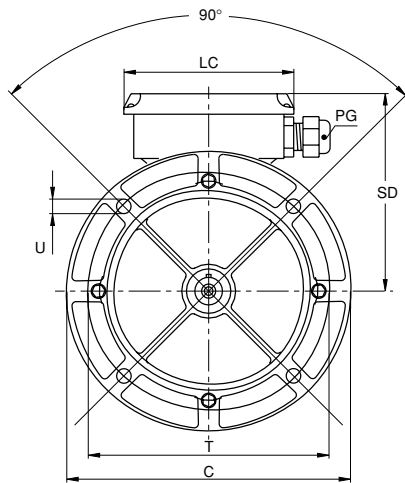

B5

Grandezza Size Grandeur Größe	Dimensioni / Dimensions / Dimensions / Abmessungen																			B5	
	D1	D	I	B	C	T	G	M	NA	O*	PG	R	SD	U	PB	Q	LC	DC	IB		P
56	9	9	20	80	120	100	2,5	8,5	212	-	M16	110	108	7,0	255	3	93	15	20	232	90
63	11	11	23	95	140	115	2,5	10,0	239	233	M16	123	117	9,5	288	3	93	12	23	262	98
71	11	14	30	110	160	130	3,0	10,0	266	245	M16	137	124	9,5	322	3	93	23	23	296	98
80	14	19	40	130	200	165	3,0	11,0	298	278	M20	156	141	12,0	371	3	115	26	30	338	111
90S	14	24	50	130	200	165	3,5	10,0	310	325	M20	176	150	12,0	395	5	115	29	30	360	129
90L	14	24	50	130	200	165	3,5	10,0	335	350	M20	176	150	12,0	420	5	115	29	30	385	129
100	24	28	60	180	250	215	4,0	14,0	377	404	M20	194	159	14,5	492	5	115	33	50	437	139
112	24	28	60	180	250	215	4,0	14,0	409	388	M20	218	172	14,5	525	6	115	35	50	469	161
132S	28	38	80	230	300	265	4,0	20,0	482	463	M32	258	192	14,5	628	6	123	48	60	562	186
132M	28	38	80	230	300	265	4,0	20,0	520	500	M32	258	192	14,5	666	6	123	48	60	600	186
160M	42	42	110	250	350	300	5,0	20,0	627	602	M32	315	246	18,5	856	9	187	56	110	737	242
160L	42	42	110	250	350	300	5,0	20,0	671	645	M32	315	246	18,5	900	9	187	56	110	781	242
180	-	48	110	250	350	300	5,0	20,0	725	-	M32	348	260	19,0	-	-	187	51	-	835	320

O* = Quota per freno serie S
Grandeza 200 autofrenante disponi-
bile su richiesta

O* = Value for series S brake
Size 200 self-braking available on
request

O* = Cote pour frein série S
Grandeur 200 freinage automatique
disponible sur commande

O* = Wert für die Bremse Serie S
Größe 200 selbstbremsend auf Anfra-
ge erhältlich

**Dimensioni motori trifase
autofrenanti e doppia
polarità autofrenanti
serie AT - AD - AH - AI -
TA** - AS - AC**

**Dimensions of three-
phase brake motors and
two-speed brake motors
series AT - AD - AH - AI -
TA** - AS - AC**

**Dimensions of three-
phase brake motors
triphases autofreinants et
à double polarité
autofreinants série AT - AD
AH - AI - TA** - AS - AC**

**Abmessungen der
Drehstrombremsmotoren
und der polumschaltbaren
Bremsmotoren Serie AT -
AD - AH AI - TA** - AS - AC**

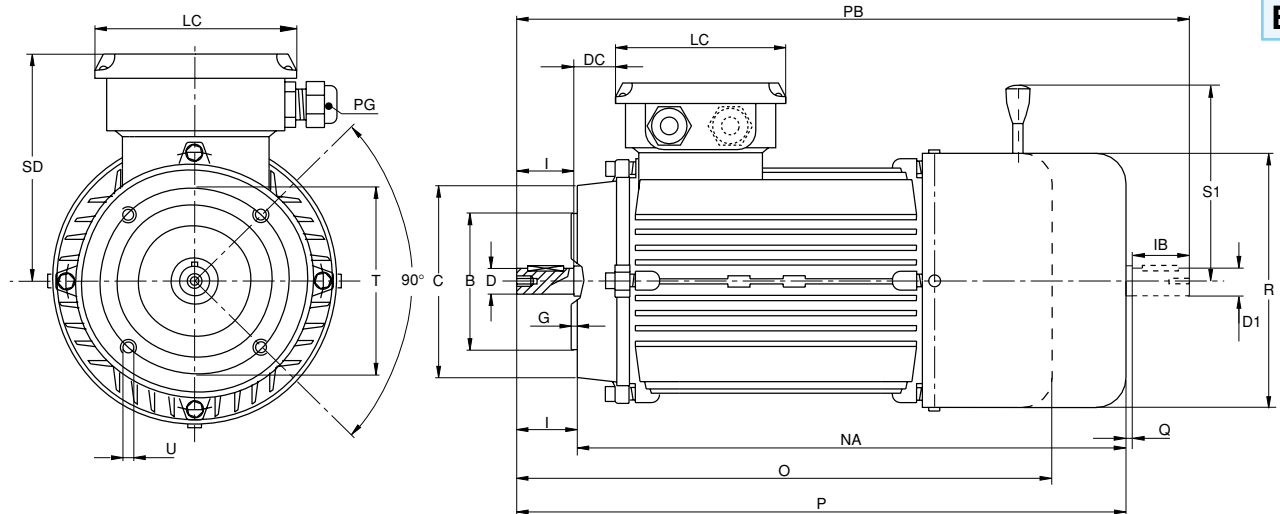

B14

Grandezza Size Grandeur Größe	Dimensioni / Dimensions / Dimensions / Abmessungen																			B14
	D1	D	I	B	C	T	G	NA	O*	PG	R	SD	U	PB	Q	LC	DC	IB	P	
50B	-	9	20	50	80	65	2,5	178	-	M16	100	105	M5	-	-	93	3,5	-	198	-
56	9	9	20	50	80	65	2,5	212	-	M16	110	108	M5	255	3	93	15,0	20	232	90
63	11	11	23	60	90	75	2,5	239	233	M16	123	117	M5	288	3	93	12,0	23	262	98
71	11	14	30	70	105	85	3,0	266	245	M16	137	124	M6	322	3	93	23,0	23	296	98
80	14	19	40	80	125	100	3,0	298	278	M20	156	141	M6	371	3	115	26,0	30	338	111
90S	14	24	50	95	140	115	3,0	310	325	M20	176	150	M8	395	5	115	29,0	30	360	129
90L	14	24	50	95	140	115	3,0	335	350	M20	176	150	M8	420	5	115	29,0	30	385	129
100	24	28	60	110	160	130	4,0	377	404	M20	194	159	M8	492	5	115	33,0	50	437	139
112	24	28	60	110	160	130	4,0	409	388	M20	218	172	M8	525	6	115	35,0	50	469	161
132S	28	38	80	130	200	165	4,0	482	463	M32	258	192	M10	628	6	123	48,0	60	562	186
132M	28	38	80	130	200	165	4,0	520	500	M32	258	192	M10	666	6	123	48,0	60	600	186
160M	42	42	110	180	250	215	4,0	627	602	M32	315	246	M12	856	9	187	56,0	110	737	242
160L	42	42	110	180	250	215	4,0	671	645	M32	315	246	M12	900	9	187	56,0	110	781	242

O* = Quota per freno serie S
Grandezza 200 autofrenante disponibili su richiesta
B14 - grandezze 180 / 200 disponibili su richiesta

O* = Value for series S brake
Size 200 self-braking available on request
B14 - sizes 180 / 200 available on request

O* = Cote pour frein série S
Grandeur 200 freinage automatique disponible sur commande
B14 - grandeurs 180 / 200 disponibles sur commande

O* = Wert für die Bremse Serie S
Größe 200 selbstbremsend auf Anfrage erhältlich
B14 - Größen 180 / 200 auf Anfrage erhältlich