

Albero lento semplice
Single output shaft
Standard Abtriebswelle

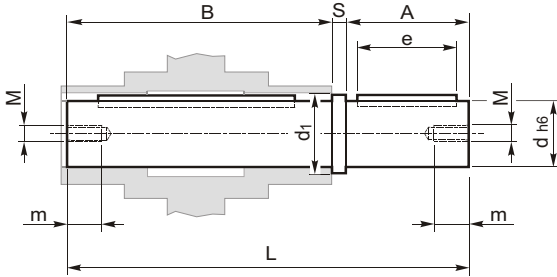

X-H	A	A _b	B	B _b	d	d ₁	e	L	L _b	M	m	S	S _b
30	30	29	62	64	14	18.5	20	94.5	125.5	M6	16	2.5	2.5
40	40	38.8	77	79.2	18	23.5	30	120	161	M6	16	3	3
50	50	50	90	93.2	25	31.5	40	143.5	196.7	M8	22	3.5	3.5
63	50	48.8	111	113.2	25	31.5	40	165	216	M8	22	4	4
75	60	58.5	119	121.5	28	34.5	50	183	244	M8	22	4	4
90	80	78.5	139	141.5	35	41.5	60	224	305	M10	28	5	5
110	80	77.3	154.5	156.9	42	49.5	60	242.5	322	M10	28	8	8

Albero lento doppio
Double output shaft
Doppelte Abtriebswelle

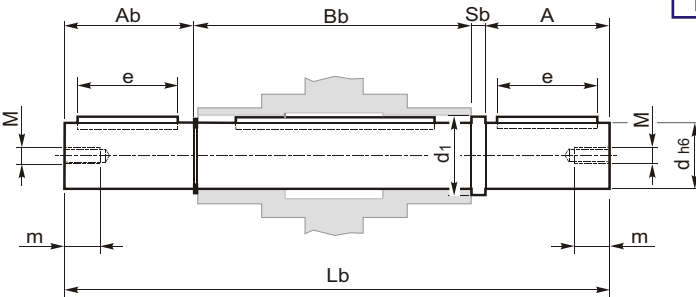

Braccio di reazione
Torque arm
Drehmomentstütze

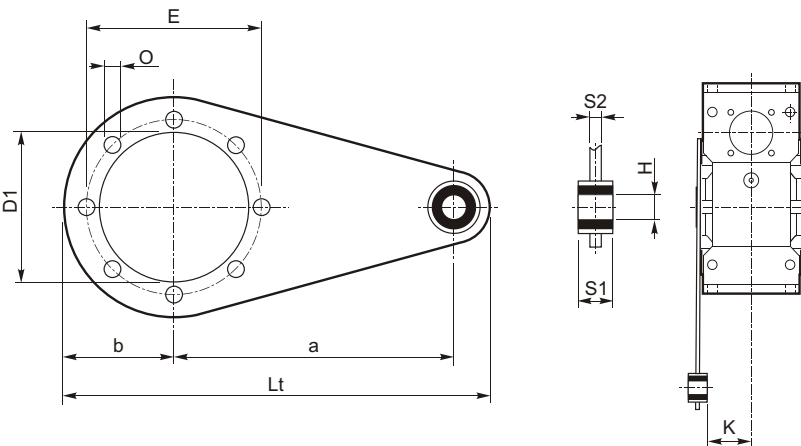

X-H	a	b	D ₁	E	H	K	L _t	O	S1	S2
30	85	37.5	55	65	8	24	141.5	7	14	4
40	100	45	60	75	10	31.5	167	7	14	4
50	100	50	70	85	10	39	172	9	14	5
63	150	55	80	95	10	49	227	9	14	6
75	200	70	95	115	20	47.5	302	9	25	6
90	200	80	110	130	20	57.5	312	11	25	6
110	250	100	130	165	25	62	390	11	30	6

Opzione disponibili:

- Seconda entrata
- Dispositivo antiritorno
- Calettatore
- Limitatore di coppia cavo passante

Available options:

- Second input
- Backstop device
- Shrink disc
- Through hollow shaft torque limiter

Auf Anfrage ist folgendes Zubehör erhältlich:

- Zweiter Antrieb
- Rücklaufperre
- Schrumpfverbindungsscheibe
- Drehmomentenbegrenzer mit durchgehen mit durchgehender Hohlwelle